

PENETRANTS • GREASES • LUBRICANTS • OILS

CASE STUDY KROIL & SUPER LUBE HELP TRIOSIM SERVICE THE PULP & PAPER INDUSTRY



Triosim is a diverse network of companies with broad knowledge and expertise in pulp, paper and other industries. The Triosim Field Service division provides expert maintenance and repair of critical production equipment. This includes the execution of inspection services and proactive preventive maintenance during planned shutdown periods to help avoid unscheduled downtime. Whether planned or not, shutdowns can be very expensive for the pulp & paper industry. Planned downtime can cost an organization from \$30,000 to \$50,000 per hour, and unplanned downtime costs can skyrocket to \$80,000 to \$150,000 per hour.

The Challenge

Triosim Field Service teams typically consist of forty millwrights and a supervisor, who work on-site at their customers' facilities. They operate out of a fleet of 53ft semi-truck trailers, which are fully outfitted with the tools, equipment and specialized machinery needed for the specific customer they are servicing. Projects include precision maintenance and repair, troubleshooting, process improvements, replacement parts and more, and teams work around the clock for as long as needed to complete each job. Pulp and paper machinery is made up of thousands of moving parts, which are often covered in thick wood dust, greasy substances and rust. In order to service this equipment, Triosim techs are always on the lookout for bolts, bearings, gears and other parts that have become gunked-up or seized-up. Left untended, these issues can result in equipment malfunctions and stoppages.

DID YOU KNOW?

\$65 BILLION+

Estimated size of the North American Pulp & Paper market by 2029

\$80K-\$150K

Hourly cost of unplanned downtime in the Pulp & Paper Industry

400 MILLION METRIC TONS

Annual global production of paper and cardboard products

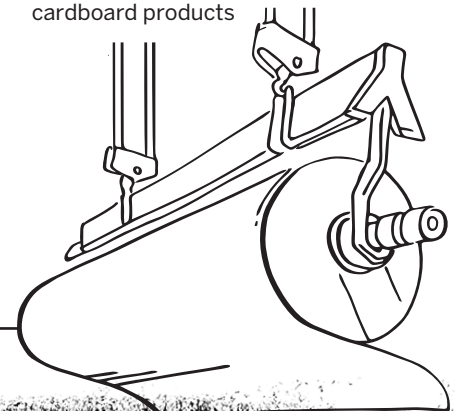

How Does Kroil Solve the Problem?

HEAR FROM INDUSTRY PROS



The Solution

KROIL & SUPER LUBE

To help complete the toughest jobs, Triosim Field Service trailers and toolboxes are regularly stocked with Kroil and Super Lube® products. Kroil Original Penetrant is used to help loosen and extract rusted bolts, and tap threads for new ones. Without Kroil, extra time would be required to break old bolts, resulting in hours of expensive downtime. Super Lube Multi-Purpose Synthetic Grease is used for packing gears and anything that requires grease, as well as nylon surfaces that have become coated in limescale. Super Lube Multi-Purpose Synthetic-Aerosol Lubricant is used to prep and maintain the many tools used by the Triosim team, including chains, knocker wrenches and spanner wrenches. This precoat step alone saves thousands of dollars in tool replacements.



The Results

“We use many different products, and our techs ask for Kroil because it works. It’s more expensive, but it works better and saves us hundreds of dollars on the backend. These guys have been doing this for 20-30yrs, and there’s a reason why they choose Kroil.”

“You can buy one can of Kroil or you can buy three cans of a competitor. There’s a reason why it works so well. Don’t give me the cheaper stuff. Don’t change it.”

“When techs ask for specific products, like Super Lube grease, I order it. These guys are very brand loyal. When they ask for brands, they have a reason behind it. They know the quality of the product.”

ELIJAH “ELI” TATE, TOOLING & LOGISTICS COORDINATOR, TRIOSIM CORPORATION



Kroil



Find all Industrial Grade Kano Products at www.Kroil.com or contact sales@kanolabs.com

Kano Laboratories LLC (henceforth Kano Laboratories) warrants its products to be free from defects in material and workmanship. Any recommendation or suggestion relating to the use of its products, whether in its technical literature, or in response to specific inquiry, or otherwise, is based on data believed to be reliable; however, the products and information are intended for use by Buyers having requisite skill and know-how in the industry, and therefore it is for the Buyer to satisfy itself of the suitability of the products for its own particular use, and it shall be deemed that Buyer has done so, at its sole discretion and risk. Kano Laboratories makes no other warranties concerning its products whatsoever including any warranty of merchantability or warranty of fitness for a particular purpose. All products are sold as-is.

©2024 Kano Laboratories LLC

Super Lube

